

# GOBI JEEP GRAND CHEROKEE WL 2 & 3 ROW ROOF RACK FRONT SUN ROOF INSERT INSTALLATION INSTRUCTIONS

## Guidelines:

When using Load Carriers and Accessories, the user must understand the precautions. The points listed below will assist you in using the rack /carrier system and will encourage safety.

- For quality fits and safty, use only the recommended rack or accessory. Do not assume an accessory will fit, always check with dealer when obtaining new accessories. Use only approved accessories on load carriers. Using other brands will void your warrenty.
- Make sure all knobs, bolts, screws, straps, and locks are firmly attached, tightened and locked before every trip. Knobs, bolts, screws, straps, and locks must be periodically inspected for signs of wear, corrosion, and fatigue. Check your load at stops during the trip to insure continued fastening security.
- Check local and state laws governing projection of objects beyound the width of a vehicle. **Be aware of the width and height of your cargo since low clearance branches, bridges, and parking garages can affect the load** All cargo will affect the vehicle's driving behavior. Never drive with any lock, know, or rack in an open or unlocked position. All long loads such as, but not limited to sailboards, surfboards, kayaks, canoes, and lumber must be tied down front and rear to the bumpers or tow hooks, of the vehicle.
- Remove your rack accessories when they are not in use, before intering car washes, prior to taking in your vehicle for service, and whenever clearance may be an issue.
- All locks must be turned and moved periodically to insure smooth operation. Use graphite or similar dry lubricant to help this. Locks are designed to deter vandalism and theft. Remove valuable gear if your vehicle is unattended for an extended period. Place at least one key in the glove compartment.
- For safety to your vehicle and rack system, obey all posted speed limits and traffic cautions. Adapt your speed to the conditions of the road and the load being carried.
- Do not use load carriers and accessories for purposes other than those for which they were designed. Do not exceed their carrying capacity.
- Consult with your dealer if you have any questions regarding the operations and limits of this product. Review all instructions carefully.

**CAUTION: USE ANTI-SEIZE LUBRICANT ON ALL  
SCREWS PRIOR TO ASSEMBLY**

# GOBI JEEP GRAND CHEROKEE WL 2 & 3 ROW ROOF RACK FRONT SUN ROOF INSERT INSTALLATION INSTRUCTIONS

## Included in kit

Letter	Description	Location	Quantity
A	GOBI GRAND CHEROKEE FRONT RACK INSERT	Main box	1
B	GOBI INSERT HARDWARE CONTENTS: 4- 3/8-16 x 1-1/4" SS Carriage bolt 4- 3/8" SS Flat washer 4- 3/8" SS Nylock nut 1- Package anti-seize lubricant 4- Steel clamp plates	Located in hardware Bag attached to insert	1

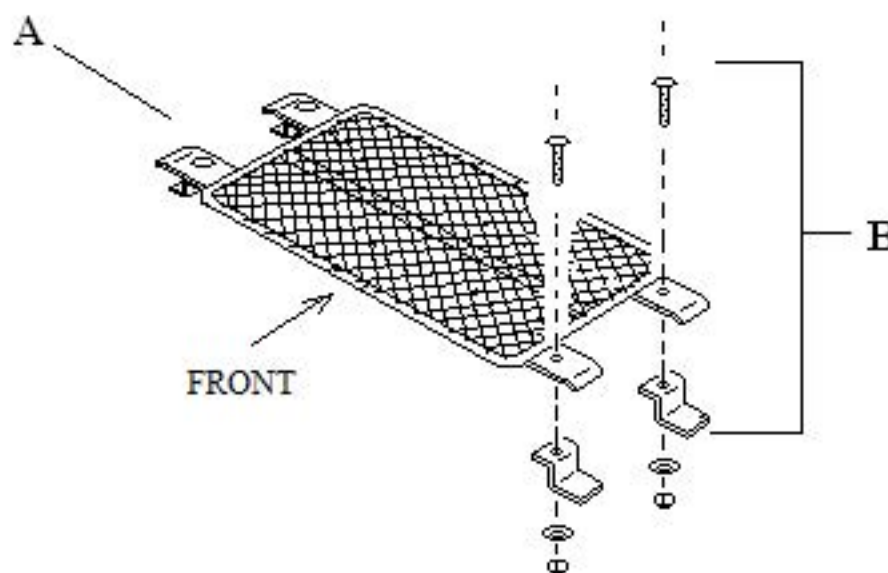

**“CAUTION”** When securing cargo to the Jeep JK insert make certain that cargo straps are tied to the roof rack **ONLY** and not the insert alone as this will insure the stability and security of the Gobi JK sun roof insert and cargo from accidental movement or dislodging.

**CAUTION: USE ANTI-SEIZE LUBRICANT ON ALL SCREWS PRIOR TO ASSEMBLY**

## GOBI JEEP GRAND CHEROKEE WL 2 & 3 ROW ROOF RACK FRONT SUN ROOF INSERT INSTALLATION INSTRUCTIONS

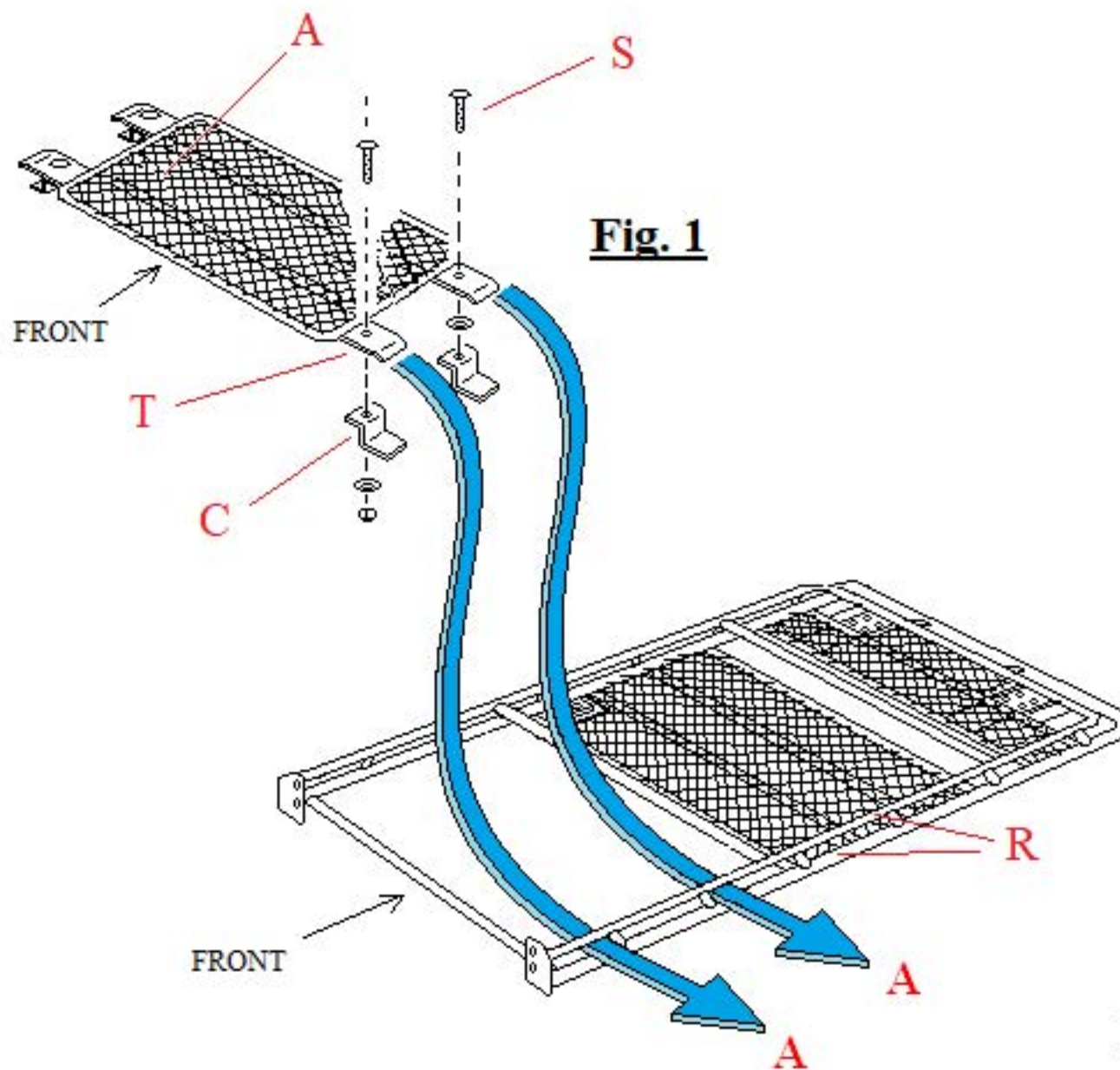

As shown in Fig. 1, make certain to remove at least one side of end clamp plates (C) from the sunroof insert (A) along with hardware (S). Then as shown in Fig. 2, slide the sunroof insert tabs (T) in between roof rack rails (R) in the direction of the blue arrows (A).

## GOBI JEEP GRAND CHEROKEE WL 2 & 3 ROW ROOF RACK FRONT SUN ROOF INSERT INSTALLATION INSTRUCTIONS

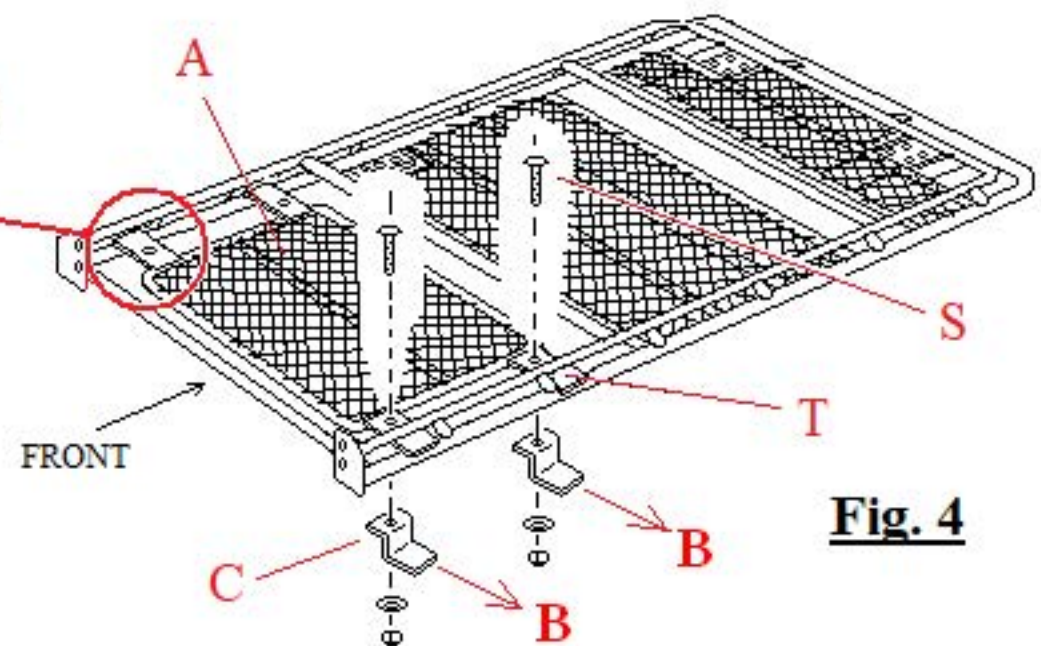
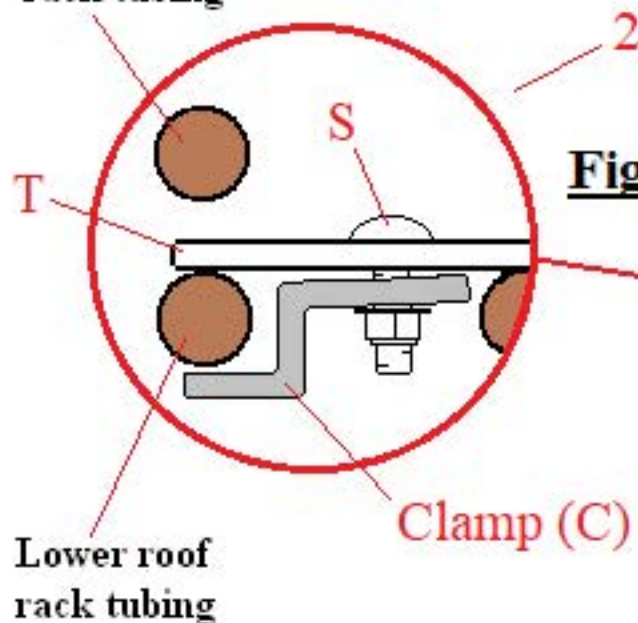
Upper roof  
rack tubing

As shown in Fig. 3 and 4, place clamp plate (C) located in hardware Bag #1, under roof rack lower tube and roof rack insert tab (T). Remove from hardware Bag #1, one 3/8-16 x 1-1/4" carriage bolt (S) and insert down through roof rack insert tab (T) then into clamp plate (C). Thread from the underside, one 3/8" flat washer and one 3/8" nylock nut. Apply the same procedure to the remaining three tabs (T) and fully tighten in place.

**INSERT INSTALLATION COMPLETED**