

GOBI HUMMER H1 ROOF RACK INSTALLATION INSTRUCTIONS

Guidelines:

When using Load Carriers and Accessories, the user must understand the precautions. The points listed below will assist you in using the rack /carrier system and will encourage safety.

- For quality fits and safty, use only the recommended rack or accessory. Do not assume an accessory will fit, always check with dealer when obtaining new accessories. Use only approved accessories on load carriers. Using other brands will void your warrenty.
- Make sure all knobs, bolts, screws, straps, and locks are firmly attached, tightened and locked before every trip. Knobs, bolts, screws, straps, and locks must be periodically inspected for signs of wear, corrosion, and fatigue. Check your load at stops during the trip to insure continued fastening security.
- Check local and state laws governing projection of objects beyound the width of a vehicle. **Be aware of the width and height of your cargo since low clearance branches, bridges, and parking garages can affect the load** All cargo will affect the vehicle's driving behavior. Never drive with any lock, know, or rack in an open or unlocked position. All long loads such as, but not limited to sailboards, surfboards, kayaks, canoes, and lumber must be tied down front and rear to the bumpers or tow hooks, of the vehicle.
- Remove your rack accessories when they are not in use, before intering car washes, prior to taking in your vehicle for service, and whenever clearance may be an issue.
- All locks must be turned and moved periodically to insure smooth operation. Use graphite or similar dry lubricant to help this. Locks are designed to deter vandalism and theft. Remove valuable gear if your vehicle is unattended for an extended period. Place at least one key in the glove compartment.
- For safety to your vehicle and rack system, obey all posted speed limits and traffic cautions. Adapt your speed to the conditions of the road and the load being carried.
- Do not use load carriers and accessories for purposes other than those for which they were designed. Do not exceed their carrying capacity.
- Consult with your dealer if you have any questions regarding the operations and limits of this product. Review all instructions carefully.

"PATENTS PENDING"

GOBI HUMMER H 1 ROOF RACK INSTALLATION INSTRUCTIONS

Included in kit

Letter	Description	Location	Quantity
A	GOBI HUMMER H1 ROOF RACK	Main box	1
B	FAIRING RUBBER PROTECTIVE STRIP	pre-assembled	1
C	FAIRING	banded to rack	1
D	FAIRING BRACKETS (pre-assembled to fairing)	pre-assembled	4
E	FAIRING BRACKET HARDWARE CONTENTS: 4 1/4-20x1 Button head screw SS 8- 1/4" Black Nylon flat washer 4 1/4-20 Zinc Nylok nut	BAG #2 Hardware Box	1
F	GOBI SUPPORT BRACKETS	Hardware Box	10
G	GOBI CROSS BARS (5- "G" Cross Bars with No Tire carrier rack)	Separate Box	4
G2	GOBI CROSS BAR (G2 cross bar only for Tire carrier rack)	Separate Box	1
H	GOBI SUPPORT BRACKET HARDWARE CONTENTS: 32 - 3/8-16 x 1-1/4" stainless steel hex bolt 62 - 3/8" stainless steel washer 30 - 3/8" Nylok lock nut 10 - rubber pad black	BAG #3 Hardware Box	1
I	GOBI DRIVING/FOG LIGHT SPACER WASHER CONTENTS: 28- washer black zinc	BAG #4 Hardware Box	1
J	Cross Bar lock nut Plate 1" x 5" x 3/8" (Only for Tire carrier rack)	Attached to Cross Bar G2	2

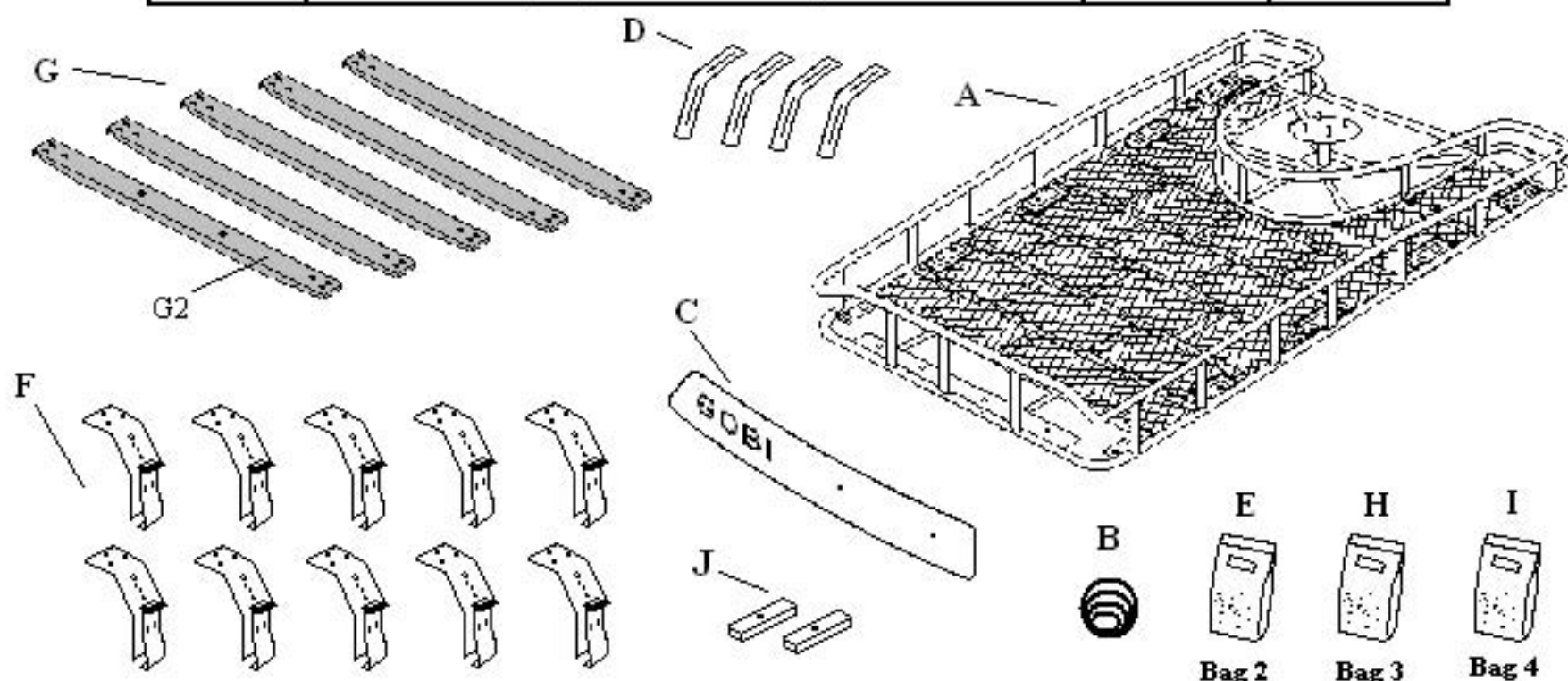

GOBI HUMMER H1 ROOF RACK INSTALLATION INSTRUCTIONS

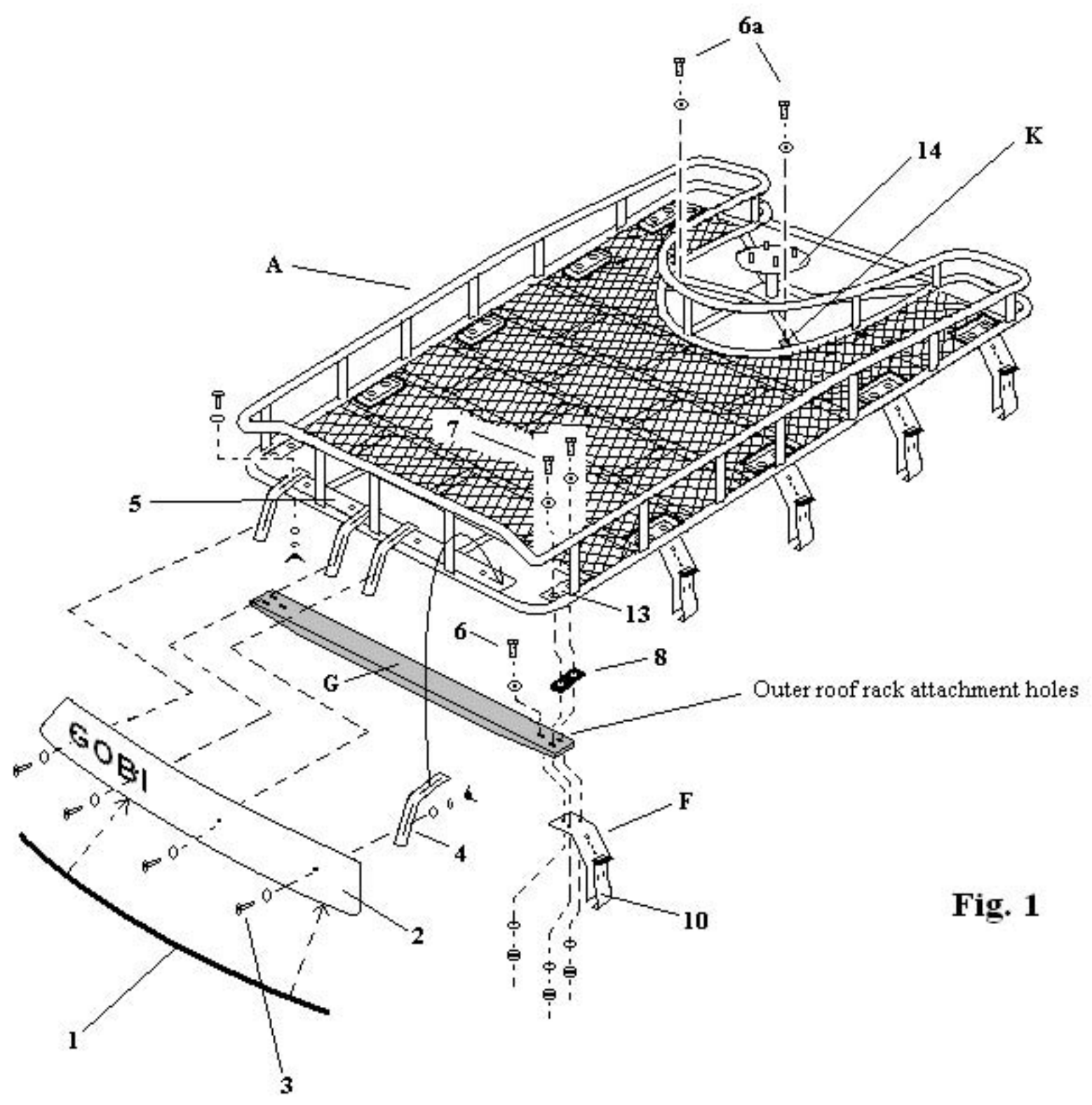

Fig. 1

GOBI HUMMER H1 ROOF RACK INSTALLATION INSTRUCTIONS

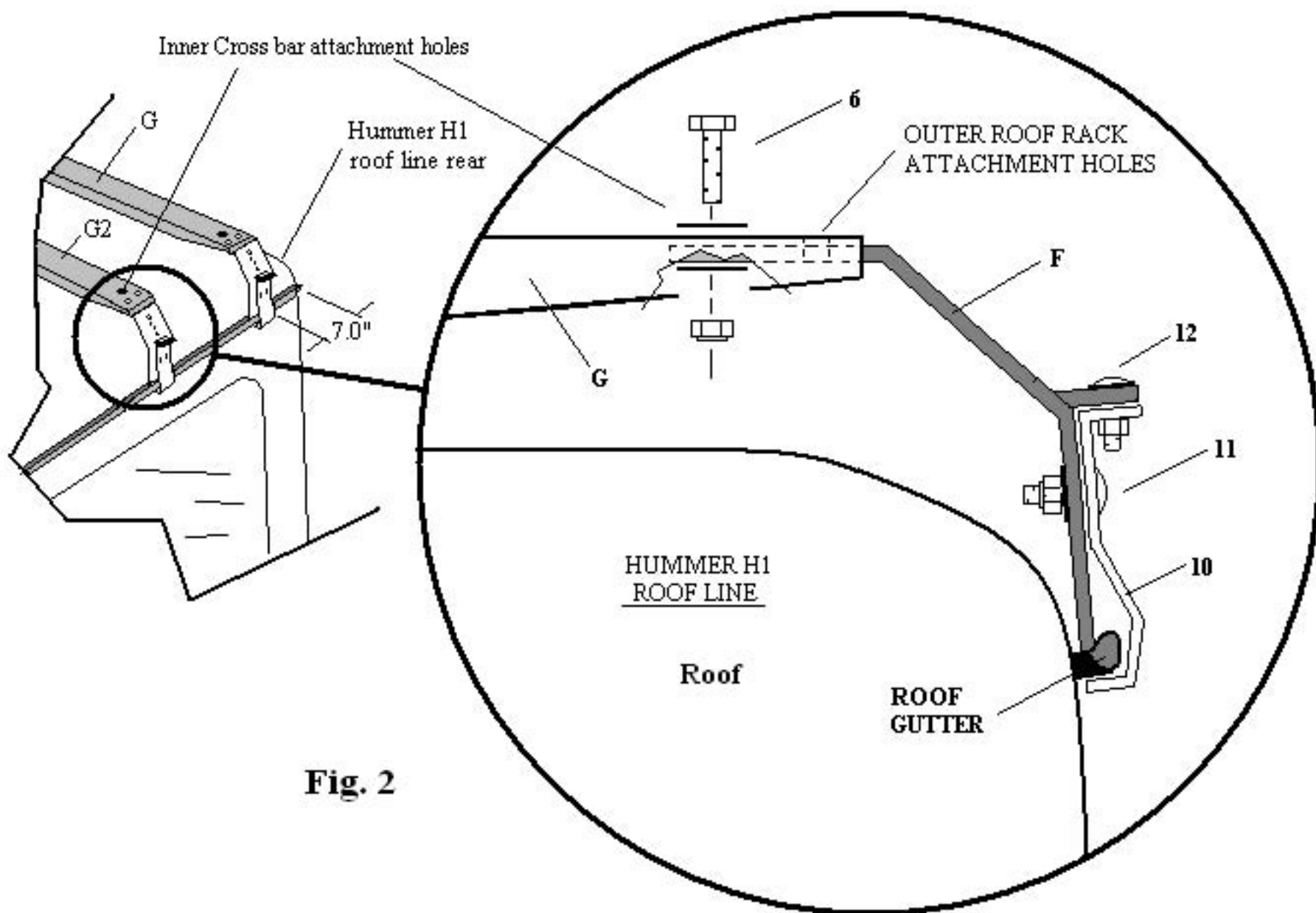

Fig. 2

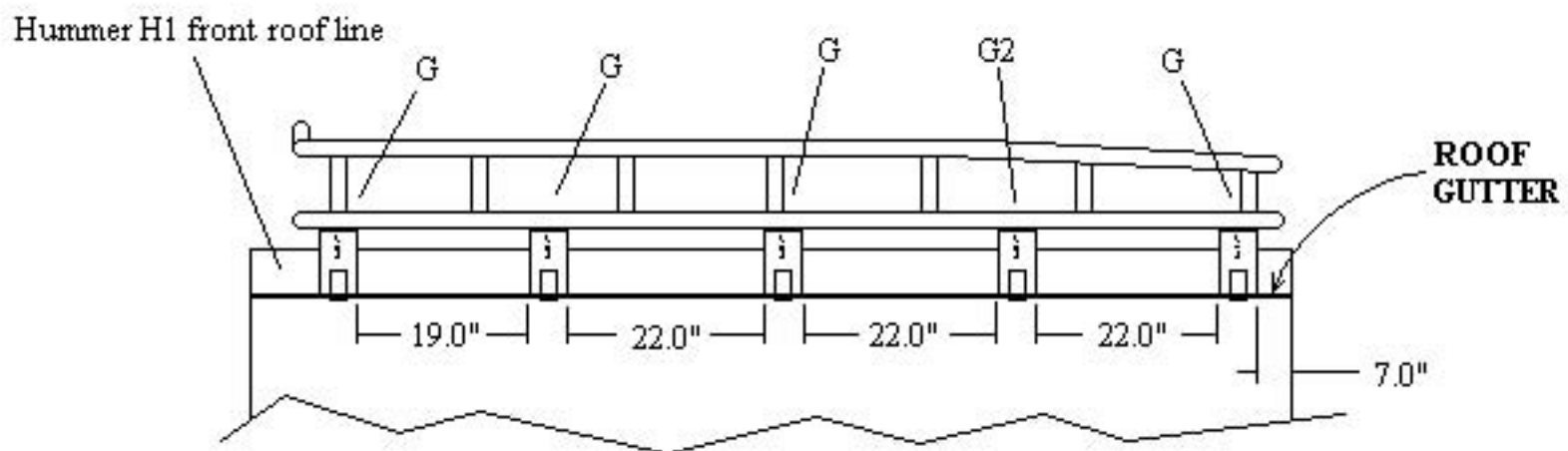

Fig. 3

GOBI HUMMER H1 ROOF RACK INSTALLATION INSTRUCTIONS

The rack must be inspected before each use to make certain attachments are secure, and for evidence of Wear. Misuse of the rack or failure to observe the manufacturer's instructions as to installation, proper Attachment and maintenance will void any warranties that may be implied by law.

1. Plastic Bag labeled #1 remove contents and press rubber protective strip #1 on to bottom of fairing #2.
2. Plastic Bag labeled #2 remove contents and place black button head screw #3 thru black washer and then thru fairing #2 as shown in Fig. 1 page 3. Place fairing onto bracket #4 and attach black washer, lock washer and wing nut finger tight only. Attach all 4 brackets but do not attach fairing to rack at this time.
3. Unpack the 5 cross bars "G" as shown in Fig. 1 page 3 and spread all 5 cross bars on a flat level surface. Remove contents from Plastic Bag labeled "H" and attach support brackets "F" into the ends of all 5 cross bars "G" as shown in Fig. 2 page 4. Attach only 1 bolt, washers and nut #6 Fig. 1 page 3 and Fig. 2 page 4 found in Plastic Bag "H" into the cross bar "G" ends marked "Inner Cross bar attachment holes" finger tighten only at this time. The outer two sets of holes located at the end of cross bars "G" marked "Outer roof rack attachment holes" Fig. 2 page 4 will be used to attach the rack to the cross bars at a later time.
4. With all support brackets "F" attached to cross bars "G" begin to straddle each cross bar over the roof top of the vehicle and rest each bracket "F" into the roof gutters as shown in Fig. 2 and Fig. 3 page 4. Place the first cross bar "G" 7" from the rear of the vehicle's roof line as shown in Fig. 2 and Fig. 3 page 4. Add Cross bar marked G2 to the second position as shown in Fig. 2 and Fig. 3 page 4. Continue to add each cross bar "G" towards the front of the vehicle separated by the dimensions shown in Fig. 3 page 4. Once all 5 cross bars "G" have been installed begin to tighten clamps #10 on bracket "F" as shown in Fig. 2 page 4. Prior to tightening be sure all clamps #10 are correctly placed under the vehicle gutter as shown in Fig. 2 page 4. Start by snugging down carriage bolt #11 on clamp #10 Fig. 2 to the point that the clamp has very little wiggle but not completely tight. Now begin to tighten the smaller carriage bolt #12 as shown in Fig. 2 which will pull clamp #10 upwards pinching clamp #10 to the gutter of the vehicle. Only snug down all clamps and cross bars at this time.
5. Place GOBI H1 Hummer roof rack "A" on the top of all cross bars "G" as shown in Fig. 1 page 3 and Fig. 3 page 4. Align welded in brackets #13 of GOBI roof rack "A" as shown in Fig. 1 page 3 to cross bars "G" "Outer roof rack attachment holes" shown in Fig. 1 page 3 and Fig. 2 page 4. After aligning the roof rack to the cross bars "G" slip black rubber pad #8 as shown in Fig. 1 page 3 between the roof rack welded in bracket #13 and cross bar "G" "Outer roof rack attachment holes". After all #8 pads found in Plastic Bag "H" are in place begin to insert and finger tighten all remaining bolts, washers and nuts #7 as shown in Fig. 1 page 3 found in Plastic Bag "H".
6. When all bolts and nuts have been installed properly secure the GOBI roof rack "A" to cross bars "G" and "G2" by completely tightening all bolts and nuts of cross bars "G" and "G2" to GOBI roof rack "A". Once roof rack "A" is completely tightened and secured to cross bars "G" and "G2" and support brackets "F" begin to tighten all clamps #10 of support bracket "F" as shown on Fig. 2 page 4 but do not over tighten carriage bolts #12 as roof gutter may be damaged. After each clamp #10 is pulled up tightly by carriage bolt #12 to roof gutter completely tighten down clamp #10 to support bracket "F" using both carriage bolts #11. Complete the same procedure to all 10 support brackets "F".

GOBI HUMMER H1 ROOF RACK INSTALLATION INSTRUCTIONS

INSTALLATION INSTRUCTIONS CONT.

- 7- Place the Fairing #2 with attached brackets #4 to the light bar #5 of the roof rack. Align fairing brackets #4 with the small Slots in the light bar #5. Place the screws and washers thru bracket #4 and thru light bar #5 finger tighten using the washers and nuts supplied in Plastic Bag labeled #2. Tighten the center nut and bolt first then proceed to the sides. When tightening the side nuts and bolts pull the fairing closer to the roof rack to cause a curve to form in the fairing. If the fairing becomes distorted during the tightening procedure you may need to move a bracket in or out or pivot right or left in order to provide the fairing with a smooth surface appearance. If necessary fairing brackets may be bent in order to remove all deformation. When installation of the fairing is complete the fairing must be tight against the vehicles roof surface and free from distortion to prevent wind chatter.
- 8- If your GOBI roof rack is equipped with a tire carrier remove the remaining 2 bolts and washers from plastic Bag "H". Align bolt 6a through roof rack bracket "K" and into cross bar lock nut plate "J" attached to cross bar "G2" as shown in Fig. 1 page 3. Lock nut plate "J" can be moved to align with bracket "K" of roof rack once aligned completely tighten bolt then continue the same procedure to the second bracket "K" and tighten completely.
- 9- Remove the protective covering on the threaded studs of the tire carrier support plate #12 at this time. Place the spare tire on top of the tire carrier support plate #14 making sure the inner rim of the spare tire is in contact with the tire carrier support plate #12. Position the tire carrier support plate #12 approximately 3/4" to 1" below the inner spare tire rim surface while the tire is resting on the surface of the roof rack. You will have to lift the tire and turn the tire carrier support plate #12 clockwise or counter clockwise a few times in order to achieve the desired distance 3/4" to 1" below the inner spare tire rim. When the tire carrier #12 has been adjusted properly install all lug nuts and tighten securely. After the spare tire has been tightened down completely the face of the tire in contact with the roof rack will form slightly around the roof rack tubing this is normal and will prevent the spare tire from moving during transport.